



**Technical specifications**

Max pressure: **100 bar**  
 Oil capacity: **16 l/min**  
 Temperature: **-20-90°C**  
 Max back pressure: **5 bar**

**Applications**

Excavator

**Dimensions**

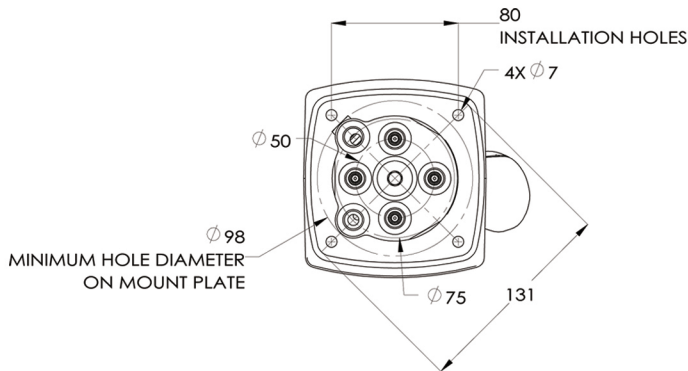

**Hydraulic schematic**

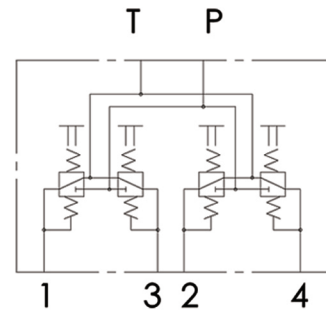

**Pressure curve**

